



Two-dimensional electronic spectroscopy in the UV

im Rahmen des Exzellenzclusters „Munich Centre for Advanced Photonics „(MAP)

Two-Dimensional (2D) spectroscopy is a pump and probe wavelength resolved ultrafast technique that gives a deep insight into the quantum molecular dynamics on the femto-second time scale. 2D electronic spectroscopy has been pioneered, over the past few years, in the study of biological & artificial light harvesters and has clarified important aspects of energy-transfer dynamics.

The existing 2D-UV spectrometer fully builds on the newly developed ability to shape sub-20 fs UV pulses at arbitrary wavelengths and first 2D experiments are now performed in our group. Our setup uses a collinear geometry where the required phase-locked pulses are generated in an acousto-optical pulse shaper. For probing we can use either a replica of the pump pulse or a second synchronized pulse at a differing wavelength of interest.

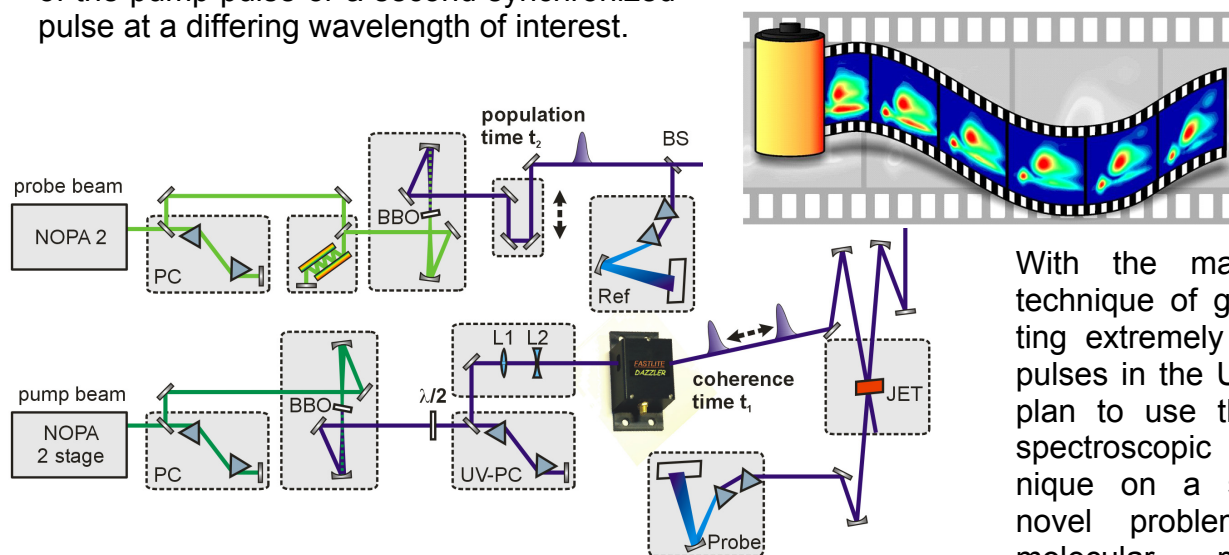

With the mastered technique of generating extremely broad pulses in the UV, we plan to use the 2D spectroscopic technique on a set of novel problems in molecular physics such as ultrafast cis-trans isomerism and excitation energy dependent dynamics in molecules relevant for organic chemistry, photocatalysis and artificial light harvesting.

The new PhD student is expected to operate the 2D-setup, perform the measurements and evaluate them together with the project leaders. He will thrive for a further increase of the coherent bandwidth of the pulses and establish a protocol for the reliable frequency calibration.

The labs are located in the relaxing surroundings in the centre of Munich. Candidates willing to deepen their skills in optics and molecular physics will fit into the strongly cooperative atmosphere present in our interdisciplinary workgroup. Previous experience in spectroscopy and nonlinear optics is welcome. Interested candidates should submit their CV and a short letter of motivation to:

The labs are located in the relaxing surroundings in the centre of Munich. Candidates willing to deepen their skills in optics and molecular physics will fit into the strongly cooperative atmosphere present in our interdisciplinary workgroup. Previous experience in spectroscopy and nonlinear optics is welcome. Interested candidates should submit their CV and a short letter of motivation to:

Dr. Igor Pugliesi,

LMU München, Lehrstuhl f. BioMolekulare Optik 2180-9255 igor.pugliesi@physik.lmu.de

Prof. Eberhard Riedle,

LMU München, Lehrstuhl f. BioMolekulare Optik 2180-9210 Riedle@lmu.de